



Russell Hobbs

INSTRUCTIONS AND WARRANTY



RHB315 Russell Hobbs Satin Blender 650W

1-year standard warranty
Warranty will be extended another year if you register your product online
within 12 months of purchase
(visit <https://russellhobbswarranty.co.za/>)



Thank you for purchasing the Russell Hobbs Satin Jug Blender. Each unit has been manufactured to ensure safety, reliability, and ease of use. Before use, please read these instructions carefully and keep them for further reference.

FEATURES OF THE RUSSELL HOBBS SATIN JUG BLENDER

- Powerful 650W motor
- 1.75L glass jug
- 5 speeds with pulse function
- Pulse function for increased control when processing
- Stainless steel blades
- Detachable blade assembly for easy cleaning
- Safety lock mechanism
- Stainless steel switch with indicator light
- Ideal for crushing ice, smoothies, cocktails, sauces and much more
- Illuminated control panel
- Removable filter cap for easy filling
- Dishwasher safe parts
- Built-in cord storage
- Non-slip feet for added stability
- Recipes included
- For domestic use only
- 1-year standard warranty. Warranty will be extended for another year if you register your product online within 12 months of purchase (visit <https://russellhobbswarranty.co.za/>)

IMPORTANT SAFEGUARDS

When using any electrical appliance, basic safety precautions should always be followed including the following:

1. Read all instructions and save the instructions provided with this appliance.
2. Do not put the motor unit in water or any other liquid; do not use it in a bathroom or near any source of water.
3. Do not use outdoors.
4. The blender must be used only by a responsible adult.
5. Switch OFF and unplug the blender from the main power supply outlet before dismantling or cleaning.
6. The blender is fitted with a safety switch to prevent the motor operating unless the jug is in place. Do not use this to switch the blender on and off.
7. Turn the switch to standby "0" / "OFF" before fitting/ removing the jug to/ from the motor/ base unit.
8. Turn the switch to standby "0" / "OFF" and wait until the blades come to a complete stop before removing the lid from the jug, and before removing the jug from the motor/ base unit.
9. This appliance is not intended for use by persons (including children) with reduced physical, sensory or mental capabilities, or lack of experience and knowledge, unless they have been given supervision or instruction concerning use of the appliance by a person responsible for their safety.
10. Children should be supervised to ensure that they do not play with the appliance.
11. Do not use the blender without first locking the lid in place.
12. Do not fill the jug with boiling liquids. Allow liquids to cool to a lukewarm temperature before you put them in the jug. This type of temperature would be comfortable to the touch.

13. Do not put your hand into the jug, even when it has been removed for cleaning – the blades are very sharp.
14. Do not come into contact with moving parts.
15. Do not put any other object (spoon, spatula, etc.) into the jug while the blender is plugged in.
16. Do not leave the blender unattended when plugged in.
17. Misuse of this appliance can result in injury.
18. Position the motor unit on a dry, firm, level surface, close to a power socket and out of reach of children.
19. Route the mains lead so that it cannot be caught accidentally or tripped over.
20. Keep the blender and the mains lead away from hotplates, hobs and burners.
21. Store the blender away from direct sunlight and fluorescent light where possible.
22. Do not let the jug overflow. If liquid gets under the motor unit, it may be sucked into the motor, damaging it.
23. Do not fill the jug above the MAX. mark. If you do, the contents may force the lid off when you start the motor.
24. The blender is equipped with a powerful motor and therefore processes very quickly. Due to its efficiency there is no need to run the motor for more than 2 minutes at a time.
25. Do not run the motor for more than 2 minutes, either continuously, or using the pulse setting, otherwise it may overheat. After 2 minutes use, switch it off for at least 2 minutes allowing it to cool to room temperature and allowing it to recover.
26. Do not use the blender for any purpose other than those described in these instructions.
27. Do not run the blender empty, as it may overheat.
28. Do not operate the blender after it malfunctions. If the mains lead or plug is damaged, return the blender to the manufacturer in order to avoid any hazard.
29. Children should be supervised to ensure that they do not play with the appliance.
30. Always turn the power off at the power outlet before you remove the plug. Remove by grasping the plug. Do not pull on the electrical cord.
31. This appliance is designed for processing household quantities; it is not suitable for commercial purposes. Use the appliance only for the purpose it was designed for.
32. Do not use this appliance if it or parts of it show visible damage or if the appliance has been dropped.
33. Do not attempt to make any modifications to this appliance.
34. To avoid any risk and to remain within warranty, repairs to this appliance must be carried out by an authorised service agent only.
35. To reduce the risk of injury, never place the blade assembly on the base without the jar properly attached.
36. If the supply cord is damaged, it must be replaced by the manufacturer, its authorised service agent or similarly qualified persons in order to avoid any hazard.
37. Switch off the appliance and disconnect from the power supply before changing accessories or approaching parts that move when in use.
38. Use only accessories provided by the manufacturer for this appliance.
39. Do not run this appliance with an external timer or remote control system.

PARTS DIAGRAM

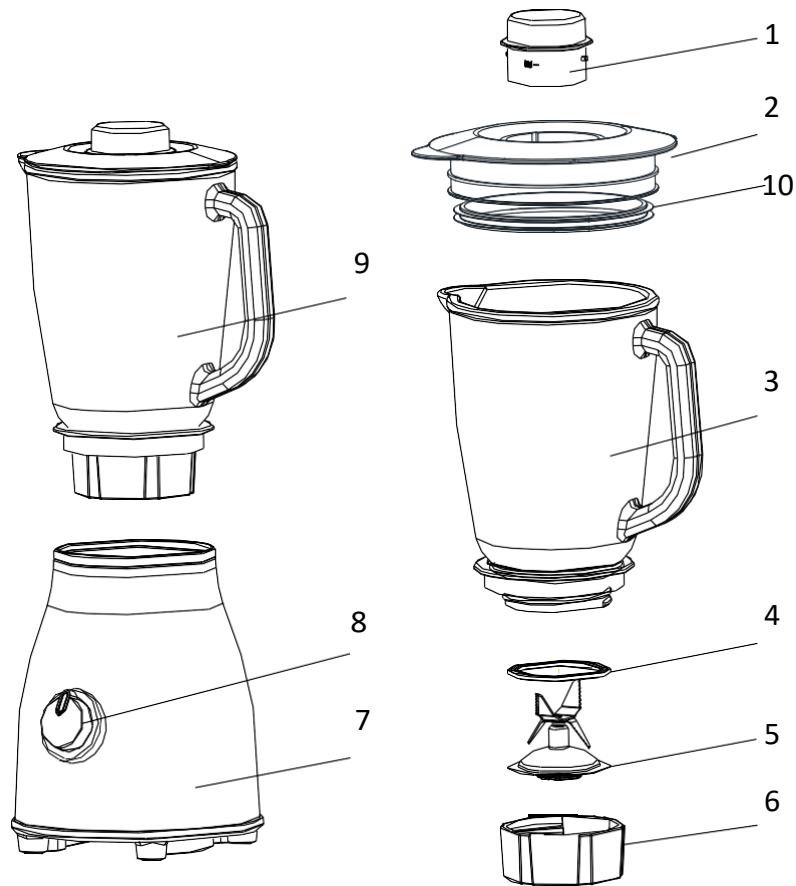

1. Measuring Cup
2. Jug Lid
3. Glass Jug
4. Blade Assembly Sealing Ring
5. Blade Assembly Unit
6. Blade Assembly Base
7. Motor Unit
8. Control Knob
9. Assembled Glass Jug
10. Jug Lid Sealing Ring

BEFORE FIRST USE

Before using your appliance for the first time take it out of the box and take off any protective wrappings. REMEMBER: DO NOT LEAVE PROTECTIVE PACKAGING LYING AROUND, AS IT COULD BE DANGEROUS AROUND INFANTS. Wash the jug, lid and cap in warm soapy water, rinse well and dry.

NOTE: The blades are sharp, handle with care.

OPERATING INSTRUCTIONS

Assembly of the Glass Jug

1. Put the sealing ring (4) on the inner edge of the blade unit (5).
2. Put the blade unit (5) with sealing ring into the blade assembly base (6).
3. Mount the glass jug (3) onto the blade assembly base. Turn the blade assembly base in a clockwise direction until it is correctly tightened in place. Be careful not to turn it too much as it may strip the thread inside the jug base unit.

4. Mount the fully assembly glass jug onto the motor/ base unit.
5. After putting the ingredients in the jug, put the lid (2) onto the jug by pressing down.
6. Insert the measuring cup (1) into the opening of the lid, and turn it in a clockwise direction until it is locked in place.

Inserting the Glass Jug

1. Position the motor unit on a dry, firm, level surface, close to a power socket and out of reach of children.
2. Make sure that the blender is switched off (Switched to the '0' setting).
3. Place the fully assembled glass jug (9) onto the motor (7).

Use

1. Place the ingredients that you wish to process into the glass jug.
2. Put the lid on the glass jug and close securely. Place the measuring cup into the hole in the lid and turn clockwise to lock. It is not a good idea to run the blender without the measuring cup in place, especially if only solid ingredients are used. They may be ejected through the hole once they hit the blades.
3. Switch on the motor:

Speed setting	Use
Low (1-3)	for light usage with liquids
High (4-5)	for more solid consistency – for mixing liquids and solid foodstuffs
P	for ice crushing & short, powerful bursts

Caution: Don't remove the lid from the jug while the blender is ON.

4. After using the blender, always move the switch into the '0' setting and remove the mains plug from the power outlet.
5. To remove the glass jug just turn it in an anti-clockwise direction and then lift it up.

Pulse Function

The pulse function will give you a short burst at maximum speed, regardless of the current speed of the blades. The button is spring-loaded. When you stop pressing, it will return to the speed the switch is pointing at.

Crushing Ice

Before using the blender to crush ice, make sure it is clean and rinse it out thoroughly. Any remaining trace of detergent may affect the taste of the crushed ice and will flatten any drink to which it has been added.

Ice cubes come in many shapes and sizes. You will have to experiment with the ice from your ice cube tray. Insert a maximum of 8 ice cubes and add 15ml (1 tablespoon) of fresh cold water. Put the lid on the blender and turn the control knob to "P". While the unit is blending, hold for 2 seconds and release for 2 seconds. Note that too much blending will reduce the ice to liquid, too little will merely chip the edges/corners off the ice. Do not try to crush ice without adding water to the jug.

Do not be tempted simply to increase the amount of ice and blend for longer – this will not work. Too much ice will never give you satisfactory results.

Adding Ingredients

If you need to add ingredients while the blender is working, lift the cap off, pour the new ingredients through the hole then replace the measuring cup. Make sure that the added ingredients do not push the volume in the jug past the MAX. mark.

Tips for Using Your Blender

- Do not blend dry, thick or heavy mixtures for more than 60 seconds continuously. Let the appliance cool down before continue operating the appliance again.
- Do not place the lid into boiling water as it may deform.
- To achieve the best results when pureeing solid ingredients, place small portions into the glass jug one by one instead of placing a large quantity all at once.
- If you are processing solid ingredients, cut them into small pieces (2-3cm) first.
- When mixing solid ingredients start off first with a small amount of liquid. Gradually add more and more liquid through the opening in the lid.
- For stirring solid or very thick liquid ingredients we recommend that you use the blender in pulse mode to prevent the blades from becoming stuck.
- Always place your hand on top of the blender when you are operating the device.
- Be careful when processing lukewarm liquids.

SMOOTHIE RECIPES

Banana Smoothie

Ingredients:

1 Banana Peeled & Sliced

¼ Cup Oats

1Tbsp Honey

1 Tbsp Peanut Butter

100g flax seeds 150ml

Yogurt

1 Cup Ice

Method:

1. Add all ingredients into the blender.
2. Pulse it at first to break the ice.
3. Blend for about 2 minutes until smooth.

Tip

This smoothie is great for sustained energy throughout the day. The banana has high levels of potassium, helping you to quickly replenish electrolytes. (The riper a banana, the higher the sugar content). The peanut butter is high in protein and the raw oats is a Low GI filler. Flax seed is a great source of fibre and Omega 3 fatty acids, and yoghurt contains protein, calcium, riboflavin, vitamin B6 and vitamin B12.

Berry Smoothie

Ingredients:

1 Cup Strawberry, blueberry & Raspberry
150ml low fat ice cream/ frozen yogurt
1 Banana
1 Cup Ice

Method:

1. Add all ingredients into the blender.
2. Pulse it at first to break the ice.
3. Blend for about 2 minutes until smooth.

Tip.

- Strawberry – high in vitamin C and antioxidants.
- Blueberry - high level of antioxidants and may be considered the most nutritional berry.
- Raspberry - sweet taste along with vitamin C, vitamin E, and a good weight loss supplement.
- Banana - high in dietary fibre.

Coconut Smoothie

Ingredients:

1 Tin coconut milk
1 tablespoon sesame oil
1 tablespoon flax seeds
1 teaspoon vanilla extract
1 Tbsp Honey
1 Cup ice

Method:

1. Add all ingredients into the blender.
2. Pulse it at first to break the ice.
3. Blend for about 2 minutes until smooth.

Tip

- Sesame oil is a source of vitamin E which is an anti-oxidant and has been correlated with lowering cholesterol levels.
- Flax seed is a great source of fibre and Omega 3 fatty acids.

Fruit & Muesli Smoothie

Ingredients:

1½ cups low-fat milk
2 tablespoons low-fat natural or vanilla yoghurt
1 ripe banana
¼ cup chopped berries: strawberries, raspberries, blueberries
1-2 tablespoons muesli

½ Cup Rolled Oats 1
cup ice

Method:

1. Add all ingredients into the blender.
2. Pulse it at first to break the ice.
3. Blend for about 2 minutes until smooth.

Tip:

This delicious smoothie is a meal in itself, rich in protein, complex carbohydrates, dietary fibre, vitamin C and antioxidants. Sweetened naturally with berries and banana.

Green Tea Smoothie

Ingredients:

250ml Green Tea
1Tbsp Honey
1 Tsp Chopped Mint
100ml Vanilla flavoured low fat ice cream/ frozen yoghurt

Method

1. Brew a cup of green tea using 2 tea bags and chill.
3. Add all ingredients into the blender.
4. Pulse it at first to break the ice.
5. Blend for about 2 minutes until smooth.

Tip:

- Green tea has tons of antioxidants, helps boost metabolism, and stabilizes Cholesterol.
- Fresh mint works as a decongestant for illness such as the common cold.

High Fibre/ Low GI Smoothie Ingredients:

½ Papino
1Tbsp Flax Seeds 2Tbsp
Digestive Bran
1/2Cup 100% Orange juice 1/2Cup
Low Fat Cultured Yogurt 1 Tbsp
Honey
1 Cup Ice

Method:

1. Add all ingredients into the blender.

2. Pulse it at first to break the ice.
3. Blend for about 2 minutes until smooth.

Tip:

- Papaya fruit is an excellent source of dietary fibre, folate, vitamin A, C and E. It also contains small amount of calcium, iron, riboflavin, thiamine and niacin. It is also very rich in antioxidant nutrients flavonoids and carotenes, very high in vitamin C plus A, and low in calories and sodium.
- Flax seed is a great source of fibre and Omega 3 fatty acids, and yogurt contains protein, calcium, riboflavin, vitamin B6 and vitamin B12.

Low fat Chocolate Crunch Smoothie

Ingredients:

- 1 Cup 2% milk
- 1 Tbsp Cocoa Powder
- ½ Cup peanuts/ cashews 1
- Tbsp Honey
- ¼ tsp Vanilla essence 1
- Cup Ice

Method

1. Add all ingredients into the blender.
2. Pulse it at first to break the ice.
3. Blend for about 2 minutes until smooth.

Tip:

- This smoothie is low fat and delicious.
- For an iced coffee, replace the cocoa powder with instant coffee powder or a chilled espresso.

Spiced Mango Lassi

Ingredients:

- 1 Large Mango, peeled & Chopped 1
- Cup Plain Low Fat Yogurt
- 1 Tbsp Honey
- ¼ Tsp Ground Cinnamon 1/8
- Tsp Ground Cardamom
- ½ Tsp vanilla Extract 1
- Cup Ice

Method:

1. Add all ingredients into the blender.
2. Pulse it at first to break the ice.
3. Blend for about 2 minutes until smooth.

Tip:

- This rendition of India's popular yogurt shake makes a cooling counterpoint to any

spicy dish.

- For a great cocktail, add 50 ml dark rum.

Sweet Melon Smoothie (Serves 4) Ingredients:

½ Honey Melon
Thumb size Ginger, peeled 1
medium Cucumber
1 TBSP Honey
150 ml Yogurt
1 Cup Ice

Method:

1. Add all ingredients into the blender.
2. Pulse it at first to break the ice.
3. Blend for about 2 minutes until smooth.

Tip:

- Cucumbers, part of the melon family, are rich in Vitamin C and dietary fibre.
- Ginger is a great source of anti-oxidants, making this smoothie a delightfully fresh way to strengthen your immune system.

Tomato Smoothie

Ingredients:

2 tomatoes (chopped then frozen) 1
small tin of tomato juice
¼ Cup Chopped Celery juice and rind of 1/2 lemon Tbsp
Chopped basil leaves
Tabasco to taste
Salt & Pepper to taste 1
Cup Ice

Method:

1. Add all ingredients into the blender.
2. Pulse it at first to break the ice.
3. Blend for about 2 minutes until smooth.

Tip:

- Tomatoes contain vital anti-oxidants that help to fight against many diseases known today.
- Tomatoes also contain many nutrients integral for good health, such as vitamin C, A, potassium and iron to name but a few.
- Why not consider growing your own tomatoes for a continuous source of this wonder fruit.

CLEANING AND MAINTENANCE

- This appliance is for household use only and is not user-serviceable.
- Do not open or change any parts by yourself. Please refer to a qualified electrical service department or return to the supplier if servicing is necessary.
- Always remember to unplug the unit from the electrical outlet when not in use and before cleaning.
- Do not use bleach or other abrasive substance or solvents to clean your appliance as it can be damaging to the finish.
- Do not immerse the whole unit in water or any other liquid, or hold it under a running tap to clean.
- Unplug the blender from the mains before cleaning and storing away.
- Clean soon after use, to prevent residues settling inside the jug.
- Remove the jug from the motor unit. Wash the jug, lid and measuring cup in warm soapy water, rinse well, then turn the jug upside down to drain and dry.
- Keep hands out of the jug – BLADES ARE VERY SHARP.
- If it is left for too long without cleaning and bits have glued themselves to the inside of the jug, use a nylon brush to remove. If this does not work – crush a few ice cubes in it.
- Wipe the outside of the motor unit with a clean damp cloth.
- Do not put the motor unit in water or any other liquid.

Quick clean of the glass jug -

Empty the glass jug and fill it with water. Place the glass jug on the motor and turn the switch several times to the 'M' setting. Empty the glass jug and rinse until clean.

Thorough cleaning of the dismantled glass jug -

Ensure that the glass jug is completely empty before you unscrew the blade assembly. Be careful when handling the blade. All removable parts are suitable for the dishwasher. Note that the dishwasher can affect the surface finishes. Do not use harsh or abrasive cleaning agents or solvents.

STORING THE APPLIANCE

- Unplug the unit from the wall outlet and clean all the parts as instructed above. Ensure that all parts are dry before storing.
- Store the appliance in its box or in a clean, dry place.
- Never store the appliance while it is still wet or dirty.
- Never wrap the power cord around the appliance.

SERVICING THE APPLIANCE

There are no user serviceable parts in this appliance. If the unit is not operating correctly, please check the following:

- You have followed the instructions correctly
- That the unit has been wired correctly and that the wall socket is switched on.
- That the mains power supply is ON.
- That the plug is firmly in the mains socket.

If the appliance still does not work after checking the above:

- Consult the retailer for possible repair or replacement. If the retailer fails to resolve the

problem and you need to return the appliance, make sure that:

- The unit is packed carefully back into its original packaging.
- Proof of purchase is attached.
- A reason is provided for why it is being returned.

If the supply cord is damaged, it must be replaced by the manufacturer or an authorised service agent, in order to avoid any hazard. If service becomes necessary within the warranty period, the appliance should be returned to an approved Home Of Living Brands (Pty) Limited service centre. Servicing outside the warranty period is still available, but will, however, be chargeable.

CHANGING THE PLUG

If necessary, the fitted plug can be changed provided the wires in the mains lead are connected in accordance with the below colour code diagram. The plug needs to correspond with the current indicated on the packaging.

WARNING: If your appliance has three wires (Green/Yellow, Blue, Brown) then it **MUST** be earthed. Connect a three pin plug as shown below

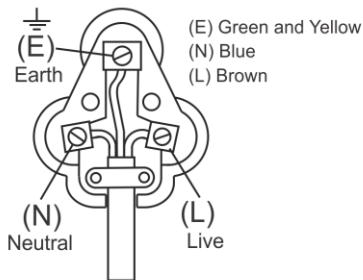

If your appliance has only two wires (Blue, Brown) then it does not need to be earthed. Connect a three pin plug as shown below

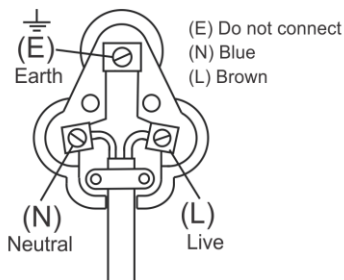

**PLEASE AFFIX YOUR PROOF OF PURCHASE/RECEIPT HERE
IN THE EVENT OF A CLAIM UNDER WARRANTY THIS RECEIPT MUST BE PRODUCED.**

1 YEAR STANDARD WARRANTY

Warranty will be extended for another year if you register your product online within 12 months of purchase (visit <https://russellhobbswarranty.co.za/>)

W A R R A N T Y AND EXTENDED WARRANTY

1. Home of Living Brands (Pty) Limited ("Home of Living Brands") warrants to the original purchaser of this product ("the customer") that this product will be free of defects in quality and workmanship which under normal personal, family or household use and purpose may manifest within a period of 1 (one) year from the date of purchase ("warranty period").
2. Home of Living Brands shall extend the warranty period for a further period of 1(one) year ("extended warranty period*"), on condition that the purchaser registers the product on the website, within 12 months from the date of purchase of the product. The website address for registration is as follows:
<https://russellhobbswarranty.co.za/>.
3. Where the customer has purchased a product and it breaks, is defective or does not work properly for the intended purpose, the customer must notify the supplier from whom the customer bought the product ("the supplier") thereof within the warranty period or if applicable, the extended warranty period. Any claim in terms of this warranty must be supported by a proof of purchase. If proof of purchase is not available, then repair, and/or service charges may be payable by the customer to the supplier.
4. The faulty product must be taken to the supplier's service centre to exercise the warranty.
5. The supplier will refund, repair or exchange the product in terms of this warranty subject to legislative requirements. This warranty shall be valid only where (a) the customer is not the cause of the product breaking, and (b) the product has been used for the intended purpose stipulated in the product manual. The warranty does not include and will not be construed to cover products damaged as a result of disaster, misuse, tamper, abuse or any unauthorised modification or repair of the product.
6. This warranty will extend only to the product provided at the date of the purchase and not to any expendables attached or installed by the customer. In this regard any accessories supplied with the product by the supplier, may be excluded in this warranty or extended warranty (see Exclusions to Warranty and Extended Warranty document).
7. If the customer requests that the supplier repairs the product and the product breaks or fails to work properly within 3 (three) months of the repair and not as a result of misuse, tampering or modification by or on behalf of the customer, then the supplier may replace the product or pay a refund to the customer, subject to the supplier's discretion.
8. The customer may be responsible for certain costs where products returned are not in the original packaging, or if the packaging is damaged. This will be deducted from any refund paid to the customer.

HOME OF LIVING BRANDS (PTY) LTD (JOHANNESBURG)

JOHANNESBURG
CAPE TOWN
DURBAN

TEL NO. (011) 490-9600
TEL NO. (021) 552-5161
TEL NO. (031) 303-1163

www.homeoflivingbrands.com
www.russellhobbs.co.za
www.facebook.com/RussellHobbsSA

EXCLUSIONS TO WARRANTY AND EXTENDED WARRANTY

1. Any accessories supplied with the product, including but not limited to, bowls, jugs, mills or carafes made either of glass or plastic and supplied with this appliance (hereinafter referred to as “the accessory or accessories”), is warranted to be free from material and workmanship defects for the duration of the appliance warranty.
2. The accessories should give trouble free service when used in accordance with the directions described in the instruction manual. However, the accessories will be damaged if subjected to impact, and this damage is not covered by the warranty. Such impact damage can occur either from the outside (if for example it is dropped or knocked against a hard surface), or from within (if for example foreign objects are placed within the accessories and the power is switched on).
3. Should you need to replace an accessory during the warranty period; a claim for a free replacement will only be considered if the item (including all shards and broken parts) is returned to the nearest HOLB service centre for examination.
4. The remains of the accessory will be carefully examined by the relevant professionals and if it is determined (at the sole discretion of HOLB) that the damage was caused by impact, then the claim will be refused and will not be covered by the warranty or any extended warranty.
5. Any replacement part provided in terms of clause 4 above will become a chargeable item payable by the customer.