



Russell Hobbs

INSTRUCTIONS & WARRANTY



MODEL NO: RHPF12

RUSSELL HOBBS COPPER PEDESTAL FAN

Congratulations on purchasing our Russell Hobbs Pedestal Fan. Each unit is manufactured to ensure safety and reliability. Before using this appliance for the first time, please read the instruction manual carefully and keep it for future reference.

FEATURES OF THE RUSSELL HOBBS COPPER PEDESTAL FAN

- 16" metal Pedestal fan
- Stylish Copper Finish
- 3 speed settings
- Oscillating function
- Tilt adjustable
- 50W
- Sturdy Round Base
- 4 Metal Blades
- Adjustable Height
- For Domestic Use Only

IMPORTANT SAFEGUARDS

When using any electrical appliance, basic safety precautions should always be followed including the following:

1. When using any electrical appliance, basic safety precautions should always be followed including the following:
2. Please read the instructions carefully before using any appliance.
3. Always ensure that the voltage on the rating label corresponds to the mains voltage in your home.
4. Incorrect operation and improper use can damage the appliance and cause injury to the user.
5. The appliance is intended for household use only. Commercial use invalidates the warranty and the supplier cannot be held responsible for injury or damage caused when using the appliance for any other purpose than that intended.
6. Avoid any contact with moving parts.
7. This appliance is not intended for use by persons (including children) with reduced physical, sensory or mental capabilities, or lack of experience and knowledge, unless they have been given supervision or instruction concerning use of the appliance by a person responsible for their safety.
8. Children should be supervised to ensure that they do not play with the appliance.

9. Check the power cord and plug regularly for any damage. If the cord or the plug is damaged, it must be replaced by the manufacturer or a qualified person in order to avoid an electrical hazard.
10. Do not use the appliance if it has been dropped or damaged in any way. In case of damage, take the unit in for examination and/or repair by an authorised service agent.
11. To reduce the risk of electric shock, do not immerse or expose the motor assembly, plug or the power cord to water or any other liquid.
12. Never immerse the full unit in water or any other liquid for cleaning purposes.
13. Remove the plug from the socket by gripping the plug. Do not pull on the cord to disconnect the appliance from the mains. Always unplug the unit when not in use, before cleaning or when adding or removing parts.
14. The use of accessory attachments that are not recommended or supplied by the manufacturer may result in injuries, fire or electric shock.
15. A short cord is provided to reduce the hazards resulting from becoming entangled in or tripping over a longer cord.
16. Do not let the cord hang over the edge of a table or counter. Ensure that the cord is not in a position where it can be pulled on inadvertently.
17. Do not allow the cord to touch hot surfaces and do not place on or near a hot gas or electric burner or in a heated oven.
18. Do not use the appliance on a gas or electric cooking top or over or near an open flame.
19. Use of an extension cord with this appliance is not recommended. However, if it is necessary to use an extension lead, ensure that the lead is suited to the power consumption of the appliance to avoid overheating of the extension cord, appliance or plug point. Do not place the extension cord in a position where it can be pulled on by children or animals or tripped over.
20. This appliance is not suitable for outdoor use. Do not use this appliance for anything other than its intended use.
21. Do not carry the appliance by the power cord.
22. Do not leave this appliance unattended during use. Always unplug the unit when not in use or before cleaning.
23. Always operate the appliance on a smooth, even, stable surface. Do not place the unit on a hot surface.
24. Ensure that the switch is in the "Off" position after each use.
25. The manufacturer does not accept responsibility for any damage or injury caused by improper or incorrect use, or for repairs carried out by unauthorised personnel.

26. In case of technical problems, switch off the machine and do not attempt to repair it yourself. Return the appliance to an authorised service facility for examination, adjustment or repair. Always insist on the use of original spare parts. Failure to comply with the above mentioned pre-cautions and instructions, could affect the safe operation of this machine.
27. The fan should be placed on a flat and stable surface when operating to avoid overturning.
28. The fan should not be placed, used or stored in a damp area or where humidity is high.
29. The fan blades are sharp and caution should be taken when assembling the unit.
30. Do not insert any objects into the fan guard when the unit is operating.

PARTS DIAGRAM

1. Front Guard
2. Fan Blade
3. Blade Screw
4. Rear Guard Screws
5. Rear Guard
6. Motor shaft
7. Oscillation Knob
8. Speed Control
9. Motor Unit
10. Connector Screw and Nut
11. Inner Pole
12. Height adjustment Knob
13. Outer Pole
14. Base
15. Heavy Weight
16. Fastener
17. Locking Screw

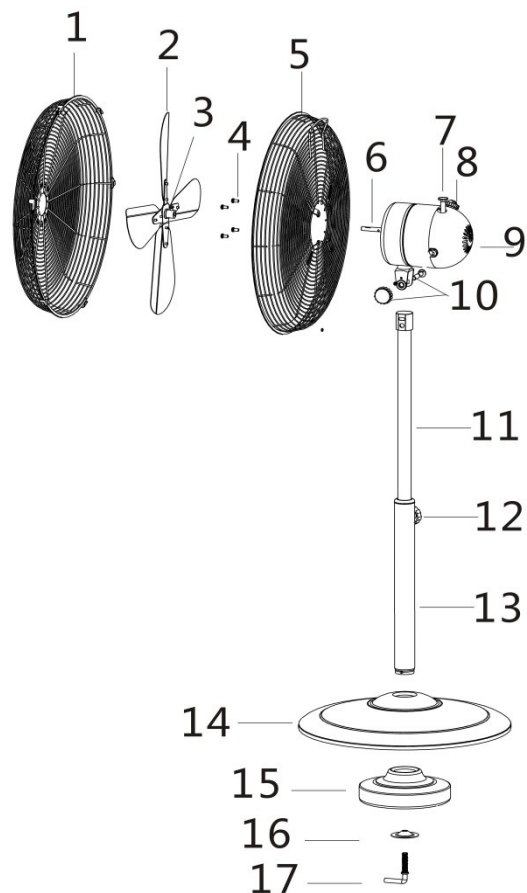

ASSEMBLY INSTRUCTIONS

Fan Grill Assembly

1. Fasten the rear guard onto the motor with the four screws.
2. Insert the fan blade into the motor shaft by tightening the blade screw.
3. Centre the front guard by aligning the logo on the guard hub so it is horizontal and parallel to the floor. Then secure the front and rear guard completely together by snapping grill clips into place.
4. Lastly, tighten the guard locking screw at the bottom of the rear guard.

Base Assembly

1. Unscrew the fastener and the base lock nut from the stand assembly.
2. Insert the stand assembly through the hole in the center of the base and twist into position.
3. Turn the stand base upside down with the stand assembly facing the floor and place the base weight support under the bottom of the base. Tighten the base weight support to the stand base by using the fastener and locking screw.
4. Finally connect the assembled fan head and stand with the connector screw and nuts, ensure that it is tightened enough.

OPERATING INSTRUCTIONS

1. Turn the speed control to select the desired speed.
2. Tilt the fan to the required angle by pushing the tilt-guard; you can adjust the fan to any position preferred.

CLEANING AND MAINTANANCE

Note: Take care not to drop the blades

1. Before cleaning, always ensure the fan is switched off and disconnected from the electrical socket.
2. Disassemble the fan guard.
3. Wipe off dust and dirt with a warm damp cloth and wipe once more with a dry cloth.
4. Do not immerse the unit in water or other liquids.
5. Never use polish or any corrosive or abrasive liquids or substances that will damage the paint, metal or plastic.
6. Reassemble the fan guard by putting back the blades and locking the guard securely before use.

STORING THE APPLIANCE

- Unplug the unit from the wall outlet and clean all the parts as instructed above. Ensure that all parts are dry before storing.
- Store the appliance in its box or in a clean, dry place.
- Never store the appliance while it is still wet or dirty.

SERVICING THE APPLIANCE

There are no user serviceable parts in this appliance. If the unit is not operating correctly, please check the following:

- You have followed the instructions correctly
- That the unit has been wired correctly and that the wall socket is switched on.
- That the mains power supply is ON.
- That the plug is firmly in the mains socket.

If the appliance still does not work after checking the above:

- Consult the retailer for possible repair or replacement. If the retailer fails to resolve the problem and you need to return the appliance, make sure that:

- The unit is packed carefully back into its original packaging.
- Proof of purchase is attached.
- A reason is provided for why it is being returned.

If the supply cord is damaged, it must be replaced by the manufacturer or an authorised service agent, in order to avoid any hazard. If service becomes necessary within the warranty period, the appliance should be returned to an approved Home Of Living Brands (Pty) Limited service centre. Servicing outside the warranty period is still available, but will, however, be chargeable.

CHANGING THE PLUG

Should the need arise to change the fitted plug, follow the instructions below.

This unit is designed to operate on the stated current only. Connecting to other power sources may damage the appliance. Connect a three-pin plug as follows:

The wires in this mains lead are coloured in accordance with the following code:

Green/Yellow = Earth

Blue = Neutral

Brown = Live

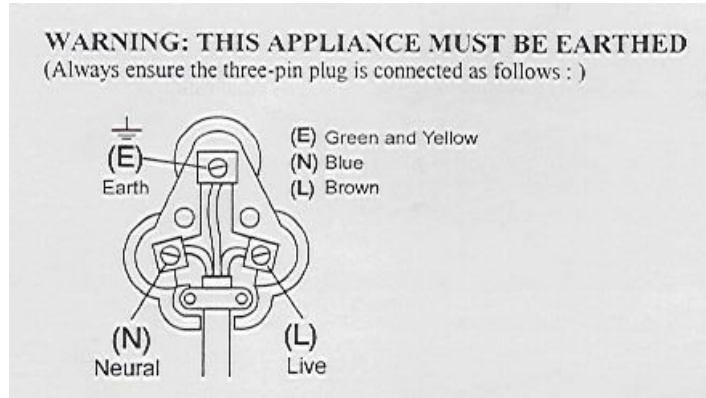

**PLEASE AFFIX YOUR PROOF OF PURCHASE/RECEIPT HERE
IN THE EVENT OF A CLAIM UNDER WARRANTY THIS RECEIPT MUST BE PRODUCED.**

2 YEAR WARRANTY
1 year retail | 1 year extended
warranty upon registration*
visit www.russellhobbs.co.za

W A R R A N T Y AND EXTENDED WARRANTY

1. Home of Living Brands (Pty) Limited ("Home of Living Brands") warrants to the original purchaser of this product ("the customer") that this product will be free of defects in quality and workmanship which under normal personal, family or household use and purpose may manifest within a period of 1 (one) year from the date of purchase ("warranty period").
2. Home of Living Brands shall extend the warranty period for a further period of 1(one) year ("extended warranty period"), on condition that the purchaser registers the product on the website, within 12 months from the date of purchase of the product. The website address for registration is as follows: <http://russellhobbs.co.za/info-pages/warranty-info.aspx>. The extended warranty period only applies to products purchased on or after 1 October 2017.
3. Where the customer has purchased a product and it breaks, is defective or does not work properly for the intended purpose, the customer must notify the supplier from whom the customer bought the product ("the supplier") thereof within the warranty period or if applicable, the extended warranty period. Any claim in terms of this warranty must be supported by a proof of purchase. If proof of purchase is not available, then repair, and/or service charges may be payable by the customer to the supplier.
4. The faulty product must be taken to the supplier's service centre to exercise the warranty.
5. The supplier will refund, repair or exchange the product in terms of this warranty subject to legislative requirements. This warranty shall be valid only where (a) the customer is not the cause of the product breaking, and (b) the product has been used for the intended purpose stipulated in the product manual. The warranty does not include and will not be construed to cover products damaged as a result of disaster, misuse, tamper, abuse or any unauthorised modification or repair of the product.
6. This warranty will extend only to the product provided at the date of the purchase and not to any expendables attached or installed by the customer. In this regard any accessories supplied with the product by the supplier, may be excluded in this warranty or extended warranty (see Exclusions to Warranty and Extended Warranty document).
7. If the customer requests that the supplier repairs the product and the product breaks or fails to work properly within 3 (three) months of the repair and not as a result of misuse, tampering or modification by or on behalf of the customer, then the supplier may replace the product or pay a refund to the customer, subject to the supplier's discretion.
8. The customer may be responsible for certain costs where products returned are not in the original packaging, or if the packaging is damaged. This will be deducted from any refund paid to the customer.

HOME OF LIVING BRANDS (PTY) LTD (JOHANNESBURG)

JOHANNESBURG
CAPE TOWN
DURBAN

TEL NO. (011) 490-9600
TEL NO. (021) 552-5161
TEL NO. (031) 303-1163

www.homeoflivingbrands.com

www.russellhobbs.co.za

www.facebook.com/RussellHobbsSA

EXCLUSIONS TO W A R R A N T Y AND EXTENDED WARRANTY

1. Any accessories supplied with the product, including but not limited to, bowls, jugs, mills or carafes made either of glass or plastic and supplied with this appliance (hereinafter referred to as "the accessory or accessories"), is warranted to be free from material and workmanship defects for the duration of the appliance warranty.
2. The accessories should give trouble free service when used in accordance with the directions described in the instruction manual. However, the accessories will be damaged if subjected to impact, and this damage is not covered by the warranty. Such impact damage can occur either from the outside (if for example it is dropped or knocked against a hard surface), or from within (if for example foreign objects are placed within the accessories and the power is switched on).
3. Should you need to replace an accessory during the warranty period; a claim for a free replacement will only be considered if the item (including all shards and broken parts) is returned to the nearest HOLB service centre for examination.
4. The remains of the accessory will be carefully examined by the relevant professionals and if it is determined (at the sole discretion of HOLB) that the damage was caused by impact, then the claim will be refused and will not be covered by the warranty or any extended warranty.
5. Any replacement part provided in terms of clause 4 above will become a chargeable item payable by the customer.

